



Client _____ Quantity _____
 Project _____ Position _____

FUN 700

Model: F70/70BRE/44X/S

Cod: MP01612123000

Technical data

Modularity:	On closed cabinet
Dimension (mm):	700x700x850
Total electric power (kW):	6,3
Cooking zone dimensions 1 (LxD mm):	fondo vasca 554x394
Nr. Wells:	1
Well litres 1:	44
Well dimensions 1 (mm):	554x394x170
Electric power (V):	380-415
Ampere (A):	10
Phases:	3N
Cable section (mmq):	5G1,5
Frequency (Hz):	50-60
Cold water inflow:	non presente
Net volume (m3):	0,417
Packing dimensions (mm):	880x856x1274
Gross weight (kg):	102
Gross volume (m3):	0,960

Features

Working top:	Made of AISI 304 stainless steel with a thickness of 10/10 mm
Material of plate:	Inox
Plate finish:	Smooth
Tipologia ribaltamento:	Manual input
Knobs:	Knobs are made from a sturdy heat-resistant polymer blend and are equipped with liquid anti-leakage washer

Electric brattpan, capacity 44 lt. Top made of AISI 304 stainless steel; covering in AISI 304 stainless steel thickness 8/10; external reinforcements made of anti-corrosion material (aluminised sheet metal); bottoms and internal parts in AISI 430 steel. Tip-up tub made of AISI 304 stainless steel with an extra thick bottom. The dimensions of the tub are 610x450x160h. mm. with a capacity of 44 lt. Equipped with heating elements located under the tub and a main switch with thermostat adjustable from 50° to 300° C. Indicator light to signal proper operation. Model with manual tub tilting by means of handwheel. Power 6.3 kW. Electrical power supply VAC 400 + 3N 50 Hz.

Technical draw

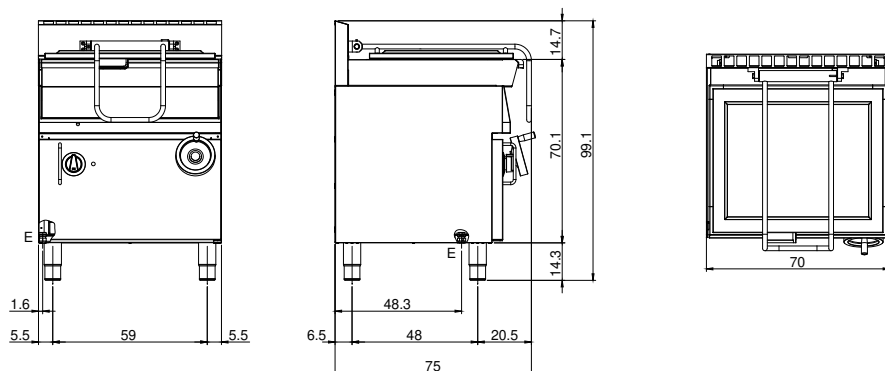

E: Electric power