



Client _____ Quantity _____

Project _____ Position _____

ROC 700

Model: R70/80PGD/50

Cod: MP01534113001

Technical data

Modularity:	On closed cabinet
Dimension (mm):	800x730x870
Total electric power (kW):	0,1
Total gas power (Kcal/h):	9029
Total gas power (kW):	10,5
Nr. Wells:	1
Well litres 1:	50
Well dimensions 1 (mm):	Ø396x445
Gas connection:	1/2"
Electric power (V):	220-240
Ampere (A):	0,5
Phases:	1
Cable section (mmq):	3G1
Frequency (Hz):	50
Hot water inflow :	3/4"
Hot water temperature (°C):	40
Hot water pressure (bar):	Max pressure 5 bar
Cold water inflow:	3/4"
Cold water pressure (bar):	Max pressure 5 bar
Drain size:	1 1/2"
Net volume (m3):	0,508
Packing dimensions (mm):	880x1026x1109
Gross weight (kg):	97,5
Gross volume (m3):	1,001

Features

Working top:	Made of AISI 304 stainless steel with a thickness of 20/10 mm
Type of heating:	Direct
Knobs:	Made of aluminum with IPX5 water protection
Water inflow:	With solenoid valve
Kit Gas:	Natural gas conversion kit 30/50 m/bar (tested with natural gas G20)

Gas boiling pan with direct heating capacity 50 liters. Side panels, bottom and back made in stainless steel. Top made in AISI 304 thickness 20/10. designed for flush alignment. Rear flue made in enamelled cast-iron. Cooking weel walls in stainless steel AISI 304 and bottom in AISI 316. Balanced lid in stainless steel AISI 304 equipped with athermic handle. Structure made in stainless steel. Thermal insulation obtained by means of high thickness panels Water charge by means of filling tap (hot and cold water) and swivel hose. Well drain hole with extractable filter. 2" front drain tap made in chromed brass with insulated handle. Heating by means of high efficiency tubular burners in stainless steel. Cooking temperature controlled by safety tap equipped with termocouple and pilot burner. Ignition by piezoelectric device. Special design knob to avoid water penetration in the control panel. Adjustable feet made in stainless steel. IPX5 protection rating. Gas total power 10,5 kW. Electric supply VAC 230 1N 50 Hz- 0.3 kW.

Technical draw

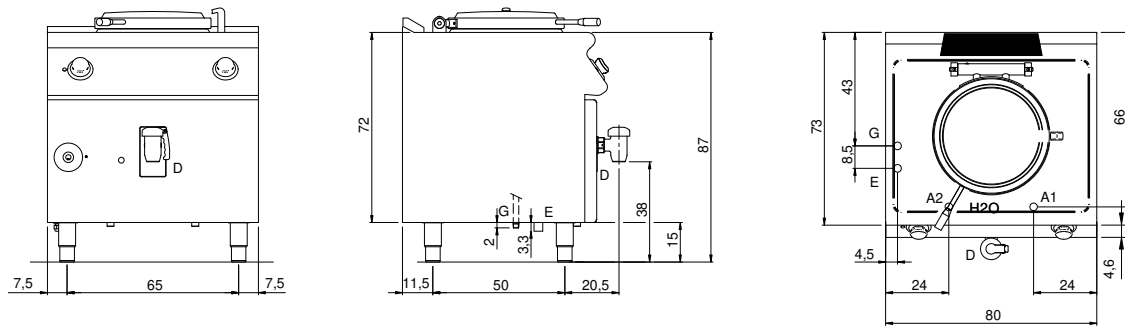

G: Gas connection 1/2"

E: Electric power

H2O: Water inflow 3/4"

A1: Hot water inflow

A2: Cold water inflow

D: Drain for water

D1: Cavity water discharge